

REV	DATE	REVISION DETAILS	APPD
A	2013/10/29	12 +/-0.2改为11.8 FULL THREAD MIN	<i>Zhangjian</i>
		12 +/-0.2 changed to 11.8 FULL THREAD MIN	Zhangjian
B	2013/10/29	增加尺寸13±0.50	<i>Zhangjian</i>
		ADD DIM.13 +/-0.50	Zhangjian

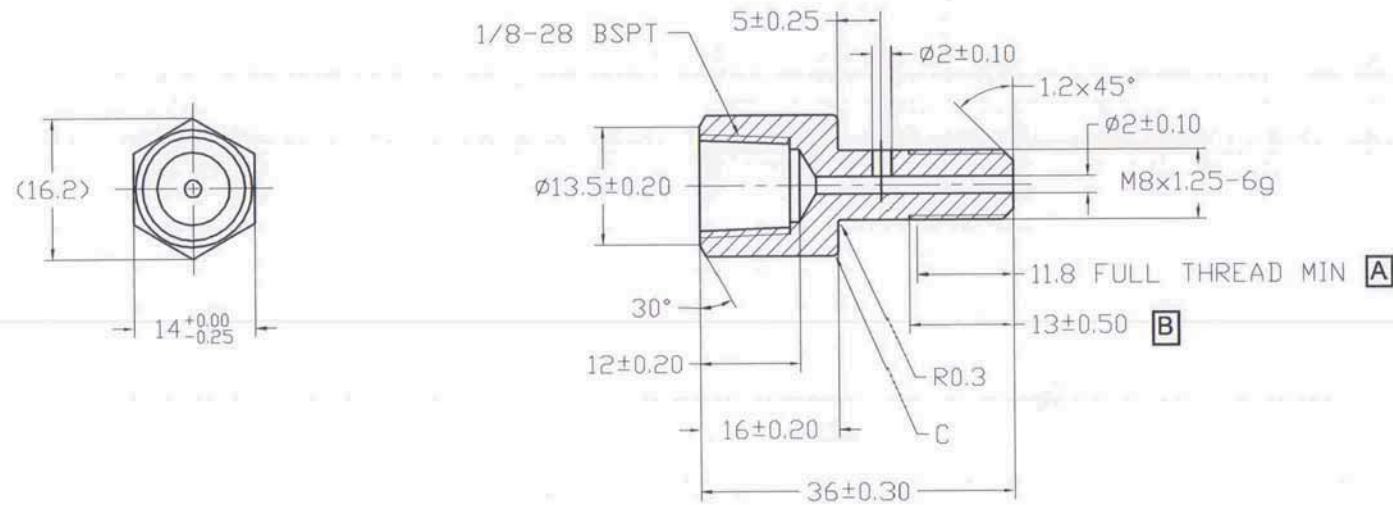

UNLESS SPECIFIED
 ALL DIMENSIONS IN mm
 MACHINED SURFACES Ra=3.2um
 ANGLE TOLERANCES ±1°
 DECIMAL TOLERANCES:

.x: ±0.5
 .xx: ±0.25
 .xxx: ±0.127

Heat treatment: quenching and tempering and HRC18-23 after heat treatment

PART No		40920-M8x1.25-R2	
SCALE:	APPD: <i>Zhangjian</i>	DRN:	Panda 2013.04.05
NTS	DATE: 31/10/13	CHK:	Panda 2013.04.05

MATERIAL	Chinese steel 45		
FINISH	Remove all sharp edges, burrs, slivers and swarf, break all edges 0.127-0.254mm. ZINC PLATED WITH TRIVALENT CHROMATE AND NO RED CORROSION IN 96 HOURS SALT SPRAY TEST.	去除所有毛刺, 铁屑等残留物, 锐边倒钝0.127 0.254mm. 镀三价铬锌, 银白色, 96小时盐雾试验无红斑。	